



Lexmark X925de

Color Laser Multifunction Product

Lexmark X925de

The Lexmark X925de color MFP delivers outstanding A3 color printing, easy-to-use features and productivity solutions, all through an affordable, compact design.



Image enhancer. Workflow advancer.



Color



10.2-Inch
Touch Screen



Copy



Scan



Fax



Solutions



A3
(11 x 17)



Up to
30 ppm



Duplex
Printing



Network

Why Lexmark?



Founded in 1991 from an IBM heritage in Lexington, Kentucky, Lexmark is focused on delivering tailored solutions to solve the unique challenges businesses face. Lexmark's broad portfolio of high-quality products, solutions and services help improve productivity, increase efficiency and empower employees to perform at their best.

Make a lasting impression with award-winning color.

The documents you print define an important image – yours. That's why Lexmark color MFPs help businesses be more productive and stand out with vibrant color. With the ability to print professional quality color in-house, you can add instant impact and save costs by virtually eliminating the need to outsource print jobs. Lexmark also offers a host of color-access and control tools to manage cost.

Eco-responsible

Printing responsibly means everyone wins—your business, your budget and the environment. Lexmark's award-winning products are designed for ease of use, high quality output and reliable performance, with innovative capabilities that help you minimize the number of cartridges you use over the life of

the printer and conserve paper and energy. Our goal is to design, package and deliver innovative products and solutions in an environmentally responsible manner.

The Lexmark Cartridge Collection Program is active around the world providing a variety of methods for free returns of your empties to Lexmark or our collection partners. Our goal: Make it easy to do the right thing.

Environmental protection is a shared responsibility

Through work with industry groups, Lexmark helps guide the formation of standards and principles for environmental sustainability.

Our memberships include:

- AeA Europe
- American National Standards Institute (ANSI)
- Ecma International
- Electronics Industry Citizenship Coalition (EICC)
- European Information & Communications Technology Industry Association (EICTA)
- Information Technology Industry Council (ITI)
- ITI Environmental Leadership Council

Overview



Affordable color input

The Lexmark XS925de delivers high quality 11x17 color multifunction performance in an affordable, compact design. Enjoy the benefits of vibrant, professional-quality output on a wide variety of media, allowing you to do more color printing in-house.

- PANTONE® calibration for consistent color tones
- Named Color Replacement for easy color matching
- Supports media up to 11.7 x 48 inches (banner)
- Lexmark Color Care Technology to manage color usage and control costs

Business productivity

The Lexmark XS925de combines high-performance printing, copying, scanning and faxing with time-saving solution applications designed to boost your productivity.

- Print and copy speeds as fast as 30 ppm in both black and color
- Advanced copy functions include the ability to interrupt long print runs to make a quick copy, and proof the first copy set before completing your copy job

- Scan to multiple destinations, including scan to email, scan to FTP, scan to fax, scan to network, and more
- Preloaded applications to drive greater efficiency, and Lexmark Embedded Solutions Framework to further extend the capabilities of the device

Easy and intuitive

The Lexmark XS925de is designed for easy operation and maintenance.

- Extra large, easy to navigate 10.2-inch color touch screen provides audible and tactile feedback to make completing tasks intuitive
- Print and scan preview features help you select documents or specific pages within a document
- Ability to change settings, such as duplex, at the device
- Robust connectivity makes it easy to integrate into almost any network environment
- Sleep Button and Hibernate Mode to reduce energy costs
- Device management software available

Solutions



Save time and money through solutions

Reduce unnecessary printing and simplify work processes through Lexmark solutions. The XS925de features the Lexmark Embedded Solutions Framework (eSF), our platform that enables you to add a wide range of software applications directly onto the device. Solutions are designed with your productivity in mind, helping you streamline—or even eliminate—paper intensive business processes.

The right touch

The Lexmark e-Task color touch screen is a key access point to your device. The extra large customizable 10.2-inch interface gives you the ability to preview thumbnails of documents prior to printing, as well as change print jobs at the device. You can even view, select and print specific pages within a document directly from the touch screen.



Its easy-to-use, intuitive navigation provides fast access to the functions and shortcuts.

Preloaded solutions* on the X925de:



Forms and Favorites

Eliminate waste and inefficiencies associated with preprinted forms. Store frequently printed forms, marketing materials or other documents online, then print them on demand.



Scan to Network

Scan a hardcopy document and route the image to one of 30 predefined personal or public shared network folders.

Examples of solutions available through Lexmark authorized partners and dealers, or through a Lexmark Professional Services engagement:



Background and Idle Screen

Change the touch screen background to your corporate logo, custom images, a unique message or select from preloaded screens.



Showroom

Display a customizable, scrolling slideshow on the color touch screen to promote your business or products, or to communicate important messages to your customers or employees.



Card Copy

Save time and effort in copying identification cards, licenses and insurance cards by automatically scanning, enlarging and printing both sides of a two-sided card onto one side of a sheet of paper.

Vertical Solutions



Education station. Solution integrated into the educational space where classroom testing and paperwork tasks can be performed with just one touch. Consists of Scan to Classroom, Print Test, Grade Test* and Forms on Demand.

Dental Assistant. Bundle of applications to help a dental office improve its common paper workflow processes. Consists of Scan to Network, Card Copy, Eco Copy, Forms on Demand, Remote Copy and Background and Idle Screen.

CPA Partner. Bundle of applications to help an accounting firm improve its common paper workflow processes. Consists of Scan to Network, Remote Copy, Eco Copy and Background and Idle Screen.

Contact your Lexmark Business Solutions Dealer for additional vertical solutions.

Lexmark's standard security features for your network, data and devices

Output security has never been more important to businesses of all sizes. Lexmark's security functions include device management, device hardening and device operation. Strong multilayered security is built-in.

Device management. Tools include administrative access and passwords, HTTPS, SNMPv3, IP security (IPSec) and 802.1x support to remotely monitor and manage device usage.

Device hardening. Includes port filtering, TCP connection filtering, hard disk encryption, hard disk wiping and digitally signed firmware updates that enhance the security of the device's network interface.

Device operation. Reduce vulnerabilities with authentication and authorization features, address book lookup via LDAP over SSL and device lockout for protection of user information.

Lexmark has shown its strength and leadership with respect to security.

- Forming and chairing the group that created the IEEE 2600 standards for security on hard-copy devices
- Becoming the first hard-copy device manufacturer to take a holistic approach with the National Information Assurance Partnership (NIAP) Common Criteria evaluation

Key Features



Lexmark X925de color MFP shown with optional paper drawers



1. 10.2-inch, color touch screen

Operate your device with ease and confidence through smart and intuitive navigation, easy access to workflow solutions and shortcuts, and the ability to preview your documents and print jobs at the device.



2. 100-Sheet automatic document feeder (RADF)

Save time by scanning both sides of your document with robust color-scanning capabilities and an input capacity of up to 100 pages.



3. Direct USB

The front USB port allows for convenient walk-up preview, printing and scanning, and is compatible with most printable image file formats.

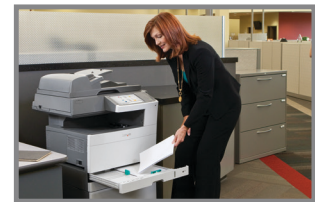

4. Load multiple media types

150-sheet and 250-sheet input trays and a multipurpose feeder come standard, allowing you to load three media types.

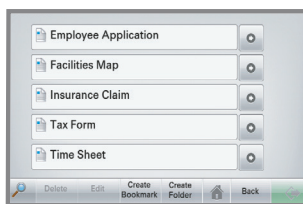

5. Lexmark solutions

Reduce unnecessary printing and simplify work processes through solution applications preloaded on your device. Choose additional Lexmark solutions to fit your unique workflow needs.



6. Eco-friendly features

Easy-to-access features like Eco-Mode reduce paper and toner consumption, the Sleep Button and Hibernate Mode make it easy to print responsibly and help you save energy.



7. Front-loading toner cartridges

Cartridges are conveniently located at the front of the device for easy access.

X925de Ordering Information

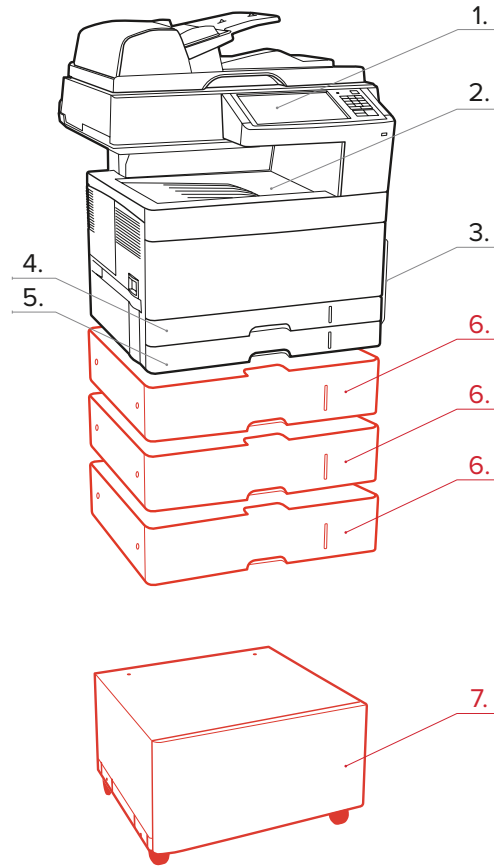

1. 10.2" Touch Screen
2. 250-Sheet Output Bin
3. 50-Sheet Multipurpose Feeder
4. 150-Sheet Input Tray
5. 250-Sheet Input Tray
6. 550-Sheet Drawer
7. Cabinet with Casters
(Use only one 550-Sheet Drawer)

Standard
 Optional

X925de

Part #	Model
24Z0653	Lexmark X925de

Part #	Laser Toner/Print Cartridge
X925H2KG	X925 Black High Yield Toner Cartridge
X925H2CG	X925 Cyan High Yield Toner Cartridge
X925H2MG	X925 Magenta High Yield Toner Cartridge
X925H2YG	X925 Yellow High Yield Toner Cartridge
C925X72G	C925, X925 Black Imaging Unit
C925X73G	C925, X925 Cyan Imaging Unit
C925X74G	C925, X925 Magenta Imaging Unit
C925X75G	C925, X925 Yellow Imaging Unit
C925X76G	C925, X925 Waste Toner Bottle

Part #	Paper Handling
24Z0030	C925, X925 550-Sheet Drawer

Part #	Furniture
24Z0031	C925, X925 Cabinet with casters

Part #	Memory Options
1025041	256MB DDR2-DRAM
1025042	512MB DDR2-DRAM
1025043	1024MB DDR2-DRAM
14F0245	256MB Flash Card
30G0287	Arabic Font Card
30G0828	Japanese Font Card
30G0825	Korean Font Card
30G0826	Simplified Chinese Font Card
30G0827	Traditional Chinese Font Card

Part #	Application Solutions
24Z0043	X925 Card for PRESCRIBE Emulation
24Z0041	X925 Forms and Bar Code Card
24Z0042	X925 Card for IPDS
57X9000	Lexmark PrintCryption Card

Part #	Connectivity
27X0025	MarkNet N8250 802.11b/g/n Wireless Print Server
14F0037	MarkNet N8120 Gigabit Ethernet Print Server
14F0042	MarkNet N8130 Fiber Ethernet 100BaseFX, 10BaseFL Print Server
14T0220	MarkNet™ N7020e Gigabit Ethernet Print Server
1021294	USB Cable (2-meter)
14F0000	Parallel 1284-B Interface Card
1021231	Parallel Cable (10-foot)
14F0100	RS-232C Serial Interface Card

Part #	Extended Warranties
2353820	X925 2-Years Total Onsite Service, Next Business Day
2353821	X925 3-Years Total Onsite Service, Next Business Day
2353822	X925 4-Years Total Onsite Service, Next Business Day
2353823	X925 5-Years Total Onsite Service, Next Business Day
2353824	X925 1-Year Onsite Service Renewal, Next Business Day

Part #	User Replaceable Parts
40X6013	C925, X925 Fuser Maintenance Kit 110-120V
40X6011	C925, X925 Transfer Belt and Roll
40X6328	X925 ADF Separator Roll
40X6432	X925 Flatbed Cushion
40X6327	X925 ADF Pick Arm

X925de Product Specifications



Product specifications	Lexmark X925de
Printing	
Display	Lexmark e-Task 10.2-inch (25.9 cm) color touch screen
Print Speed: Up to ⁴	Black: 30 ppm / Color: 30 ppm / Black (duplex): 26 spm
Time to First Page: As fast as	Black: 9 seconds / Color: 11 seconds
Print Resolution	Black: 1200 Image Quality, 600 x 600 dpi / Color: 1200 Image Quality, 600 x 600 dpi
Memory/Processor	Standard: 512 MB / Maximum: 1536 MB / Processor: Dual Core, 900MHz
Hard Disk	Included in configuration
Recommended Monthly Page Volume ²	5,000 - 10,000 pages
Maximum Monthly Duty Cycle: Up to ³	200,000 pages per month
Copying	
Copy Speed: Up to ⁴	Black: 30 cpm / Color: 30 cpm
Time to First Copy: As fast as	Black: 17 seconds
Reduce / Enlarge Range	25 - 400%
Scanning	
ADF Scan	RADF (Reversing Duplex)
Optical Scanning Resolution	600 X 600 ppi (black)
Faxing	
Features	Fax Redirect, Group Fax, Manual Fax, Fax from PC, Up to 512-Character Shortcuts, Fax Preservation, LDAP Look-up, Caller ID, Speed Dials, Block Junk Faxes, Broadcast, Fax Shortcuts, Fax Forwarding
Supplies	
Laser Cartridge Yields	8,500*-page Black High Yield Toner Cartridge / 7,500*-page Color (CMY) High Yield Toner Cartridges
Cartridges shipping with product	8,500*-page Black High Yield Toner Cartridge / 7,500*-page Color (CMY) High Yield Toner Cartridges
Paper Handling	
Paper Handling	Standard: 50-Sheet Multipurpose Feeder, 150-Sheet Input Tray, 250-Sheet Output Bin, 250-Sheet Input Tray, Integrated Duplex Optional: 550-Sheet Drawer
Paper Input Capacity: Up to	Standard: 450 pages 20 lb or 75 gsm bond / Maximum: 2100 pages 20 lb or 75 gsm bond
Paper Output Capacity: Up to	Standard: 1050 pages 20 lb or 75 gsm bond / Maximum: 1050 pages 20 lb or 75 gsm bond
Media Types Supported	Banner Paper, Envelopes, Card Stock, Labels, Refer to the Card Stock & Label Guide, Plain Paper, Transparencies
Media Sizes Supported	A6, Oficio, Universal, Statement, JIS-B5, Folio, DL Envelope, B5 Envelope, A4, 10 Envelope, 7 3/4 Envelope, 9 Envelope, A3, A5, C5 Envelope, Executive, JIS-B4, Ledger, Legal, Letter
General	
Standard Ports	Ethernet 10/100/1000 BaseTX (RJ-45), USB 2.0 Specification Hi-Speed Certified (Type B), Front USB 2.0 Specification Hi-Speed Certified Port (Type A), Rear USB 2.0 Specification Hi-Speed Certified Port (Type A)
Optional Network Ports / Optional Local Ports	Internal MarkNet™ N8250 802.11b/g/n Wireless, Internal MarkNet™ N8130 Fiber Fast Ethernet, External MarkNet™ N7020e Gigabit Ethernet, Internal MarkNet™ N8120 Gigabit Ethernet / Internal 1284-B Bidirectional Parallel, Internal RS-232C serial
Noise Level: Operating	Print: 53 dBA / Copy: 54 dBA / Scan: 54 dBA
ENERGY STAR	Yes
Specified Operating Environment	Temperature: 10 to 32°C (50 to 90°F), Humidity: 20 to 80% Relative Humidity, Altitude: 0 - 2,300 Meters (7,545 Feet)
Size (in. - H x W x D) / Weight (lb.)	30.35 x 26.46 x 26.30 in. /174.8 lb.

¹Yield at approximately 5% print coverage. ²Recommended Monthly Page Volume² is a range of pages that helps customers evaluate Lexmark's product offerings based on the average number of pages customers plan to print on the device each month. Lexmark recommends that the number of pages per month be within the stated range for optimum device performance, based on factors including: supplies replacement intervals, paper loading intervals, speed, and typical customer usage. ³Maximum Monthly Duty Cycle³ is defined as the maximum number of pages a device could deliver in a month using a multishift operation. This metric provides a comparison of robustness in relation to other Lexmark printers and MFPs. ⁴Print and copy speeds measured in accordance with ISO/IEC 24734, excludes first set of text documents. For more information see: www.lexmark.com/ISOspeeds.

Lexmark and Lexmark with the diamond design are trademarks of Lexmark International, Inc., registered in the United States and/or other countries. All other trademarks are the property of their respective owners. Information in this document is subject to change without notice. Unison is a trademark of Lexmark International, Inc. Information in this document is subject to change without notice.

AirPrint and the AirPrint logo are trademarks of Apple Inc.

